

UVGERMI®

ULTRAVIOLETS DE HAUTE TECHNOLOGIE

*Specialist in
microbiological water treatment
using ultraviolet reactors.*

● ○ ● MADE IN FRANCE

15000014_A_FT10

GERMI DP 300 ACS

> **Flow rate:** from 168.5 to 703 m³/h

Full warranty: 2 years

After-sales in France



The treatment of water for human consumption in communal facilities requires equipment that has been ACS-UV accredited in compliance with the decree of 9 October 2012 on the conditions of selling and using reactors with UV radiation lamps for the treatment of water for human consumption.



TECHNICAL SPECIFICATIONS

ACS UV no.: 24 UV LY 004, Certificate provided on request.

UV LAMP

Total electrical power:	4,800 Watts (16 lamps)
Germicidal power:	1,840 Watts UVC
Lamp service life:	16,000 hours or 2 years (maximum limit of 5 starts per 24-hour period)

UV REACTOR

Treatment chamber:	Stainless steel 316L
Input/Output:	DN 300
Operating pressure:	8 bars
Drainage valve and sampling valves	
UV sensor (permanent display of the intensity emitted)	
Temperature probe	
Automatic cleaning of the sleeves	
Adjustable foot height	

ELECTRICAL CABINET

Dimensions (mm):	800 x 1200 x 400
Power supply:	400 V Tri+N+E / 50-60 Hz
On/off switch / LCD display of lamp status / Fault display / Lamp hour counter / Painted steel cabinet	

ASSOCIATED PRODUCTS

300 W UV lamp:	14000127
Quartz sleeve:	14000052
O-rings:	14000113

OPTIONS

Vertical installation with customised feet

15000014_A_FT10

GERMI DP 300 ACS

> **Flow rate:** from 168.5 to 703 m³/h

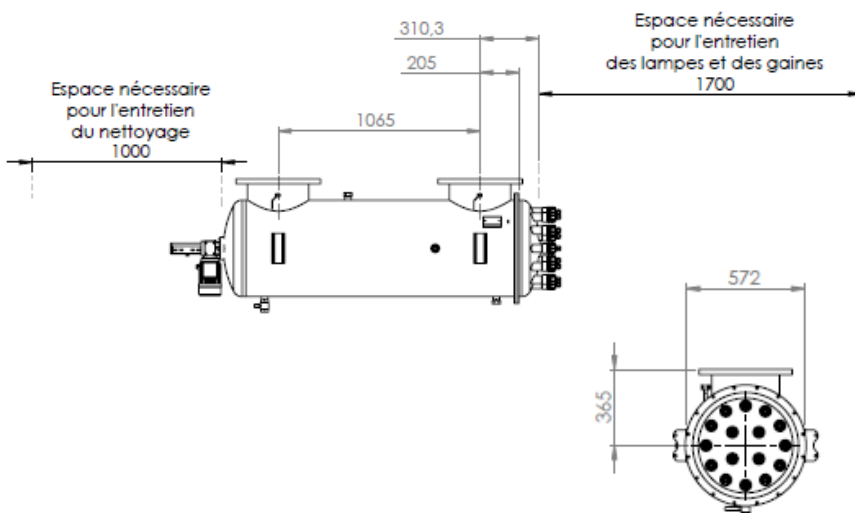

ACCREDITED FLOW RATES

TYPICAL VALUES FOR 400 J/m ²	
Maximal flow (m ³ /h)	Transmittance at 254 nm over 10 nm (%)
168.5	85
269.4	90
437.8	95
703	98

INSTALLATION

The **GERMI DP 300 ACS** is installed horizontally on the main water supply pipe. The water must flow in the direction indicated by the arrows on the UV chamber. Shut-off valves must be installed upstream and downstream of the unit.

Sufficient space must be left on the exit side of the **GERMI DP 300 ACS** (at least 1.70 m) or allow for easy dismantling of the unit (bypass) to replace the UV lamps. Pay attention to the accumulation of air in the upper part and install an air bleed if necessary.

MAINTENANCE

The reactor requires little maintenance or monitoring: check lamp service life and clogging of the quartz sleeve. Effectiveness will be reduced when the lamps approach the end of their service life. They must be replaced every 16,000 hours or every 2 years.

The quartz sleeves make lamp replacement much easier: the unit does not have to be drained or dismantled. The sleeves may become clogged and should be cleaned 1-3 times per year with a mild acid, depending on the nature of the water. The quartz sleeves must be replaced every 4 to 5 years.