

©Shutterstock.com

UVGERMI®

ULTRAVIOLETS DE HAUTE TECHNOLOGIE

Specialist in industrial water treatment solutions using ultraviolet reactors.

● ○ ● MADE IN FRANCE

18000384_A_FT10

GERMI AD 200

> **Flow rate:** from 2.59 to 6.2 m³/h



Full warranty: 1 year
After-sales in France

The **GERMI AD 200** is specifically designed for the treatment of industrial process water (rinsing, washing or recycled water), or water to be discharged or stored. It also enables the production of ultra pure water and the protection of equipment (osmosis, filtration).



TECHNICAL SPECIFICATIONS

Equipment to treat an average water flow rate of 2.59 m³/h (T₁₀ = 50% and a UV dose of at least 60 mJ/cm²) to 6.2 m³/h (T₁₀ = 70% and a UV dose of at least 40 mJ/cm²).
T₁₀ = UV transmittance over 10 mm at 254 nm.

UV LAMP

Total electrical power: 200 W (1 lamp)
Germicidal power: 58 W UVC
Lamp service life: 16,000 hours or 2 years

UV REACTOR

Treatment chamber: Stainless steel 316L
Input/Output: DN 40
Maximum pressure authorised: 6 bars
Protection rating: IP 54
Önorm UV sensor
Triangle support
Temperature probe

ELECTRICAL BOX

Dimensions (mm): 190 x 204 x 72
Protection rating: IP 52
Power supply: 230 V / 50-60 Hz
On/off switch / Lamp operation indicator
/ Hour counter / LCD display

ASSOCIATED PRODUCTS

200 W UV lamp: 14000129
Quartz sleeve: 14000048
O-ring: 14000088

OPTIONS

Automatic air bleed

18000384_A_FT10

GERMI AD 200

> **Flow rate:** from 2.59 to 6.2 m³/h

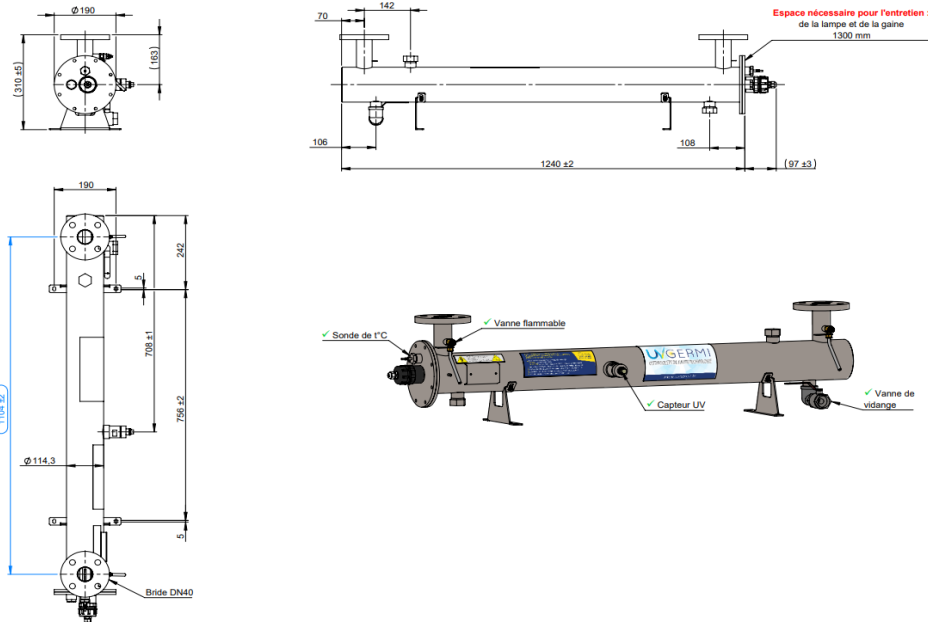

INSTALLATION

The **GERMI AD 200** is installed on the main water supply pipe. **It should be positioned horizontally**, water entry and exit are equivalent. Sufficient space must be left on the connector side of the lamp (at least 1,300 mm) or allow for easy dismantling of the unit (bypass) to replace the UV lamp.

If the reactor must be installed vertically, it must be equipped with an automatic air bleed in the upper part. If applicable, we recommend having the water enter via the bottom and exit via the top of the reactor.

The device must be protected against "water hammer" using a water hammer protection device (pressure vessel, shock absorber, etc.) if needed. It must also be protected from freezing or very hot temperatures. **We strongly recommend installing a filter upstream of the unit** to reduce the particles that might mask the UV radiation.

MAINTENANCE

Maintenance is limited to the replacement of the UV lamp and the replacement or cleaning of the sleeve. The UV lamp has a maximal service life of 16,000 hours, after which water disinfection is no longer guaranteed. The quartz sleeve protecting the lamp makes lamp replacement much easier. The quartz may become clogged or deposits may form. It can be cleaned with mild acid.