

UVGERMI

ULTRAVIOLETS DE HAUTE TECHNOLOGIE

The microbiological water treatment specialist using ultraviolet reactors.



MADE IN FRANCE

14000274B_A_FT10

GERMI AD 200 ECI*

> **Flow:** from 19.5 to 29.5 m³/h

The GERMI AD200 ECI is specially designed for securing water resources for use in industrial processes, for producing rinse or wash water, for protecting equipment (reverse osmosis, filtration), or for producing ultra-pure water.



**Full warranty: 2 years
After-sales in France**



TECHNICAL SPECIFICATIONS

Equipment for treating an average water flow between 19.5 m³/h (T₁₀ = 90% at 254 nm) and 29.5 m³/h (T₁₀ = 98% at 254 nm) for a minimum UV dose of 40 mJ/cm² at the end of lamp service life.

UV LAMP

Total electrical power: 200 Watts (1 lamp)
 Germicidal power: 58 Watts UVC
 Lamp service life: 16,000 hours or 2 years
 (limited to a maximum of 5 starts per 24 hours)

ELECTRICAL BOX

Dimensions (mm): 400 x 400 x 210
 Power: 240 V / 50-60 Hz

Lamp / UV sensor display / Fault indicator / Lamp hour counter / Painted steel cabinet / ON-OFF switch / Lights on indicator

UV REACTOR

Treatment chamber: Stainless steel 316L
 Input/Output: DN 100
 Operating pressure: 8 bar
 Drainage valve and sampling valves
 UV sensor (permanent display of the intensity emitted)
 Fixing lugs
 Temperature probe
 *ECI: Eau Claire Industrielle (Industrial Clear Water)

ASSOCIATED PRODUCTS

200 W UV lamp: 14000129
 Quartz sleeve: 15000753
 O-ring: 14000113

OPTIONS

Vertical installation

14000274B_A_FT10

GERMI AD 200 ECI*

> **Flow:** from 19.5 to 29.5 m³/h

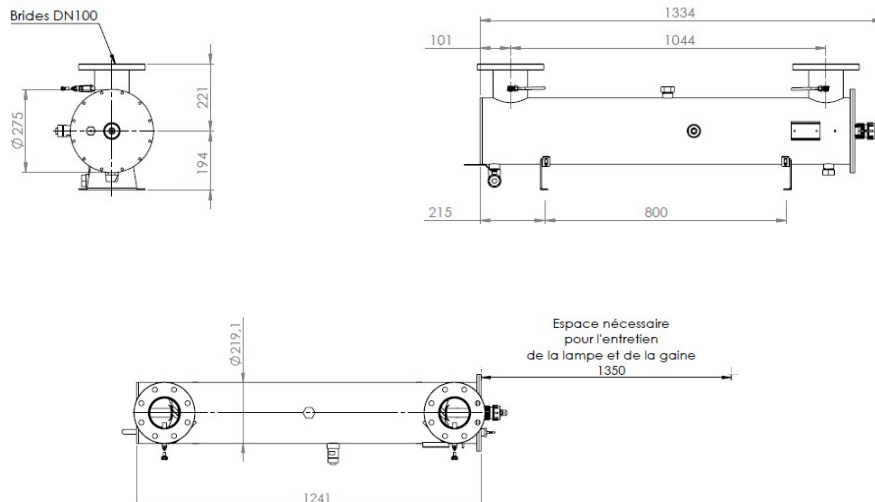

INSTALLATION

The GERMi AD200 ECI is installed on the main water supply pipe, the water inlet and outlet sides being identical. If the reactor needs to be installed vertically, an automatic air bleed must be included in the upper section of the reactor.

A gap must be left on the lamp removal side (1 m minimum) or the unit (bypass) must be easy to dismantle for maintenance operations.

MAINTENANCE

The reactor requires little maintenance and monitoring: only the lamp service life and quartz sleeve fouling need to be monitored. When the UV lamp reaches the end of its service life, efficiency losses will become noticeable. The lamp must be replaced after 16,000 hours or 2 years in operation.

The quartz sleeve considerably simplifies the replacement of the lamp, without having to drain or dismantle the entire unit. Fouling in the sleeve may occur, in which case it must be cleaned 1 to 3 times a year with a mild acid depending on the nature of the water. The quartz sleeve must be replaced every 4 to 5 years.