

©Shutterstock.com



# UVGERMI

ULTRAVIOLETS DE HAUTE TECHNOLOGIE

*The microbiological water treatment specialist using ultraviolet reactors.*



MADE IN FRANCE

14000528B\_A\_FT10

## GERMI CD 200 ECI\*

> **Flow:** from 48.5 to 74 m<sup>3</sup>/h

The GERMI CD200 ECI is specially designed for securing water resources for use in industrial processes, for producing rinse or wash water, for protecting equipment (reverse osmosis, filtration), or for producing ultra-pure water.



**Full warranty: 2 years**

**After-sales in France**



### TECHNICAL SPECIFICATIONS

Equipment for treating an average water flow between 48.5 m<sup>3</sup>/h (T<sub>10</sub> = 90% at 254 nm) and 74 m<sup>3</sup>/h (T<sub>10</sub> = 98% at 254 nm) for a minimum UV dose of 40 mJ/cm<sup>2</sup> at the end of lamp service life.

#### UV LAMP

Total electrical power: 600 Watts (3 lamps)  
Germicidal power: 174 Watts UVc  
Lamp service life: 16,000 hours or 2 years  
(limited to a maximum of 5 starts per 24 hours)

#### ELECTRICAL BOX

Dimensions (mm): 600 x 600 x 210  
Power: 240 V / 50-60 Hz  
ON-OFF switch / Lights on indicator /  
Lamps / UV sensor display / Fault indicator / Lamp  
hour counter / Painted steel cabinet

#### UV REACTOR

Treatment chamber: Stainless steel 316L  
Input/Output: DN 100  
Operating pressure: 8 bar  
Drainage valve and sampling valves  
UV sensor (permanent display of the intensity emitted) Fixing lugs  
Temperature probe  
\*ECI: Eau Claire Industrielle (Industrial Clear Water)

#### ASSOCIATED PRODUCTS

200 W UV lamp: 14000129  
Quartz sleeve: 15000753  
O-ring: 14000113



14000528B\_A\_FT10

## GERMI CD 200 ECI\*

> **Flow:** from 48.5 to 74 m<sup>3</sup>/h

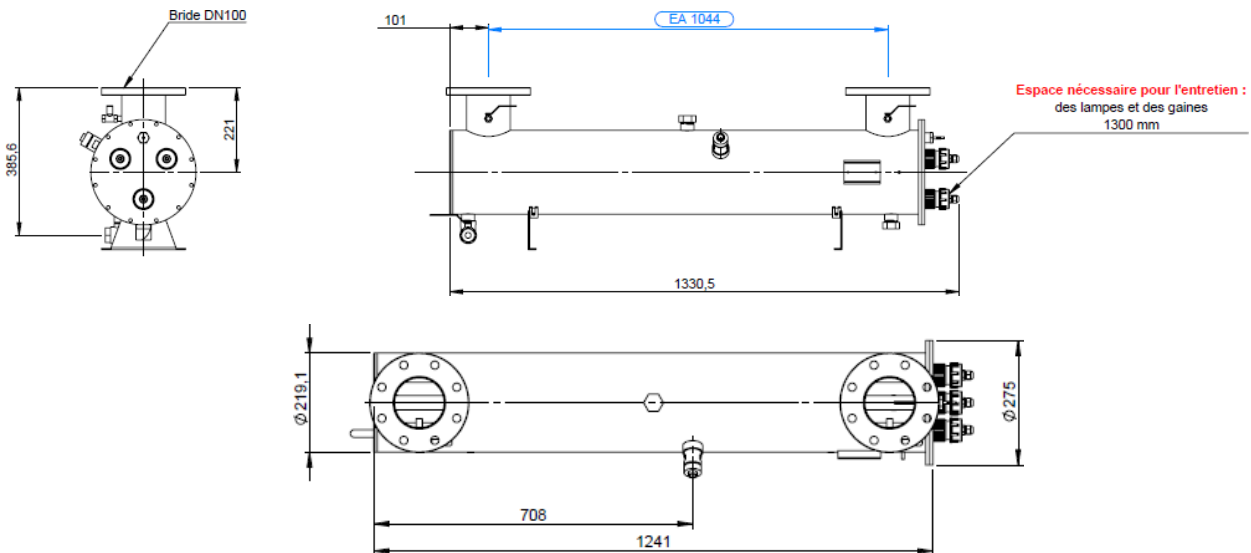

### INSTALLATION

The GERMi CD200 ECI is installed on the main water supply pipe, the water inlet and outlet sides being identical. If the reactor needs to be installed vertically, an automatic air bleed must be included in the upper section of the reactor.

A gap must be left on the lamp removal side (1 m minimum) or the unit (bypass) must be easy to dismantle for maintenance operations.

### MAINTENANCE

The reactor requires little maintenance and monitoring: only the lamp service life and quartz sleeve fouling need to be monitored. When the UV lamps reach the end of their service life, efficiency losses will become noticeable. The lamps must be replaced after 16,000 hours or 2 years in operation.

The quartz sleeves considerably simplify the replacement of the lamps, without having to drain or dismantle the entire unit. Fouling in the sleeve may occur, in which case it must be cleaned 1 to 3 times a year with a mild acid depending on the nature of the water. The quartz sleeves must be replaced every 4 to 5 years.