



UVGERMI

ULTRAVIOLETS DE HAUTE TECHNOLOGIE

The microbiological water treatment specialist using ultraviolet reactors.



MADE IN FRANCE

14000488B_A_FT10

GERMI HD 300 ECI NA*

> **Flow:** from 295 to 535 m³/h

The GERMI HD300 ECI NA is specially designed for securing water resources for use in industrial processes, for producing rinse or wash water, for protecting equipment (reverse osmosis, filtration), or for producing ultra-pure water.



Full warranty: 2 years
After-sales in France



TECHNICAL SPECIFICATIONS

Equipment for treating an average water flow between 295 m³/h (T₁₀ = 90% at 254 nm) and 535 m³/h (T₁₀ = 98% at 254 nm) for a minimum UV dose of 40 mJ/cm² at the end of lamp service life.

UV LAMP

Total electrical power: 2 400 Watts (8 lamps)
Germicidal power: 920 Watts UVC
Lamp service life: 16,000 hours or 2 years
(limited to a maximum of 5 starts per 24 hours)

ELECTRICAL BOX

Dimensions (mm): 600 x 760 x 210
Power: 240 V / 50-60 Hz
ON-OFF switch / Lights on indicator /
Lamps / UV sensor display / Fault indicator / Lamp
hour counter / Painted steel cabinet

UV REACTOR

Treatment chamber: Stainless steel 316L
Input/Output: DN 200
Operating pressure: 8 bar
Drainage valve and sampling valves
Automatic cleaning
UV sensor (permanent display of the intensity emitted)
Temperature probe
Adjustable legs (height)
*ECI: Eau Claire Industrielle (Industrial Clear Water)

ASSOCIATED PRODUCTS

300 W UV lamp: 14000127
Quartz sleeve: 14000052
O-ring: 14000113

OPTIONS

Vertical installation

14000488B_A_FT10

GERMI HD 300 ECI NA*

> Flow: from 295 to 535 m³/h

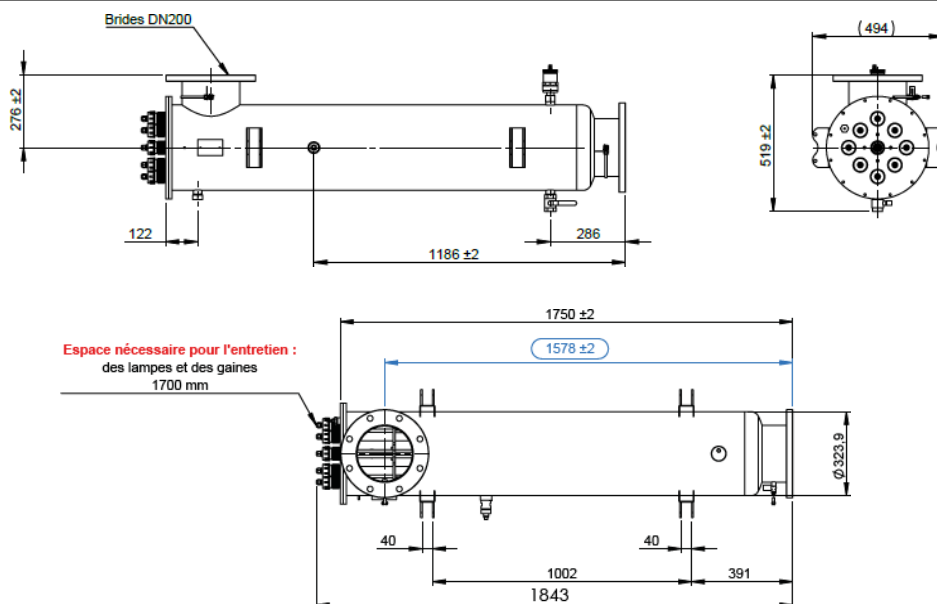

INSTALLATION

The GERM HD300 ECI NA is installed on the main water supply pipe, the water inlet and outlet sides being identical. If the reactor needs to be installed vertically, an automatic air bleed must be included in the upper section of the reactor.

A gap must be left on the lamp removal side (1 m minimum) or the unit (bypass) must be easy to dismantle for maintenance operations.

MAINTENANCE

The reactor requires little maintenance and monitoring: only the lamp service life and quartz sleeve fouling need to be monitored. When the UV lamps reach the end of their service life, efficiency losses will become noticeable. The lamps must be replaced after 16,000 hours or 2 years in operation.

The quartz sleeves considerably simplify the replacement of the lamps, without having to drain or dismantle the entire unit. Fouling in the sleeve may occur, in which case it must be cleaned 1 to 3 times a year with a mild acid depending on the nature of the water. The quartz sleeves must be replaced every 4 to 5 years.