

©Shutterstock.com

UVGERMI®

ULTRAVIOLETS DE HAUTE TECHNOLOGIE

Specialist in industrial water treatment solutions using ultraviolet reactors.

● ○ ● MADE IN FRANCE

18000395_A_FT10

GERMI LD 600 NA

> **Flow rate:** from 97 to 260 m³/h

The **GERMI LD 600 NA** is specifically designed for the treatment of industrial process water (rinsing, washing or recycled water), or water to be discharged or stored. It also enables the production of ultra pure water and the protection of equipment (osmosis, filtration).



Full warranty: 1 year

After-sales in France

TECHNICAL SPECIFICATIONS

Equipment to treat an average water flow rate of 97 m³/h ($T_{10} = 50\%$ and a UV dose of at least 60 mJ/cm²) to 260 m³/h ($T_{10} = 70\%$ and a UV dose of at least 40 mJ/cm²).
 T_{10} = UV transmittance over 10 mm at 254 nm.

UV LAMP

Total electrical power: 7,200 W (12 lamps)
 Germicidal power: 2,520 W UVc
 Lamp service life: 12,000 hours or 16 months

UV REACTOR

Treatment chamber: Stainless steel 316L
 Input/Output: DN 250
 Maximum pressure authorised: 2 bars
 Protection rating: IP 54
 Support feet
 Temperature probe
 Automatic motorised cleaning
 Önorm UV sensor

ELECTRICAL CABINET

Dimensions (mm): 800 x 1,600 x 500
 Protection rating: IP 52
 Power supply: 400 V+E+N / 50 Hz
 On/off switch / Lamp operation indicator
 / Hour counter / LCD display

ASSOCIATED PRODUCTS

600 W UV lamp: 14000100
 Quartz sleeve: 14000055
 O-ring: 15000204

OPTIONS

Automatic air bleed / Frequency 60 Hz / IP 65 cabinet

18000395_A_FT10

GERMI LD 600 NA

> **Flow rate:** from 97 to 260 m³/h

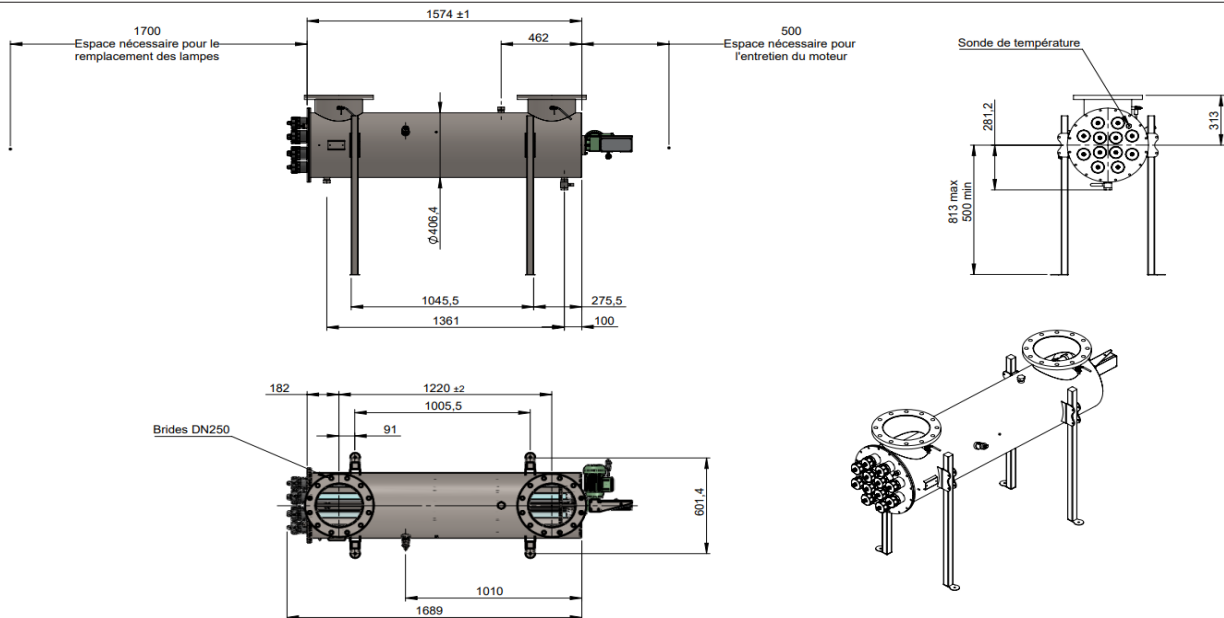

INSTALLATION

The **GERMI LD 600 NA** is installed on the main water supply pipe. It should be positioned **horizontally**, water entry and exit are equivalent. Sufficient space must be left on the connector side of the lamps (at least 1.7 m) or allow for easy dismantling of the unit (bypass) to replace the UV lamps.

If the reactor must be installed vertically, it must be equipped with an automatic air bleed in the upper part. If applicable, we recommend having the water enter via the bottom and exit via the top of the reactor.

The device must be protected against "water hammer" using a water hammer protection device (pressure vessel, shock absorber, etc.) if needed. It must also be protected from freezing or very hot temperatures. **We strongly recommend installing a filter upstream of the unit** to reduce the particles that might mask the UV radiation.

MAINTENANCE

Maintenance is limited to the replacement of the UV lamps and the replacement or cleaning of the sleeves. The UV lamps have a maximal service life of 12,000 hours, after which water disinfection is no longer guaranteed. The quartz sleeves

protecting the lamp make lamp replacement much easier. The quartz sleeves may become clogged or deposits may form. They should be cleaned with mild acid.