



UVGERMI®

ULTRAVIOLETS DE HAUTE TECHNOLOGIE

*Specialist in
microbiological water treatment
using ultraviolet reactors.*

● ○ ● MADE IN FRANCE

16000022_A_FT10

GERMI ULTRA 500 E

> Flow rate up to 800 l/h

This unit produces **drinking water** with an appropriate bacteriological content by combining filtration with UV disinfection. Bacteria and viruses are destroyed without using chemical substances.

APPLICATIONS:

Spring water, boreholes, wells, etc.



Full warranty: 1 year

After-sales in France

TECHNICAL SPECIFICATIONS

Flow treated:	800 l/h
Total electrical power:	11 W (1 lamp)
Germicidal power:	2.2 W
Lamp service life:	9,000 hour or 1 year
Filtration:	50 µm (option of 5, 10 or 25 µm, activated carbon)
Input/Output:	3/4" female
Power supply:	230 V/50-60 Hz
Maximum pressure:	3 bars

CONTROL BOX

Day counter

Audible alarm if the lamp shuts down or reaches its end of life

Light indicators for lamp operation and fault

ASSOCIATED PRODUCTS

11 W UV lamp:	17000464
Quartz sleeve:	14000049
O-ring:	14000088
50 µm filter:	17000468

1600022_A_FT10

GERMI ULTRA 500 E

> Flow rate up to 800 l/h

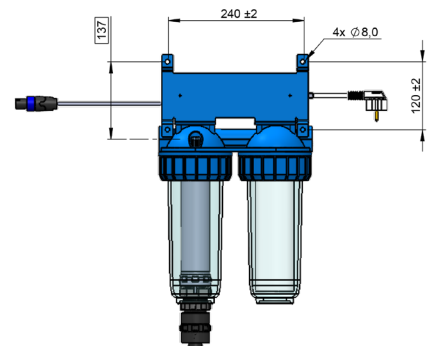
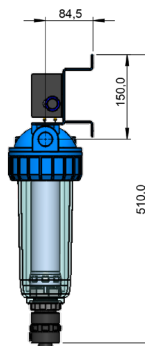
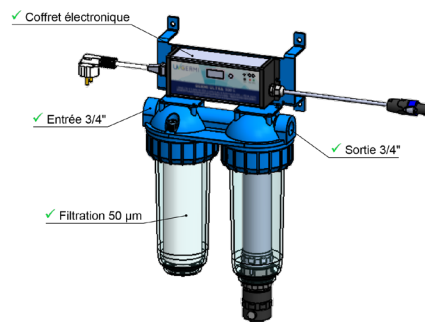
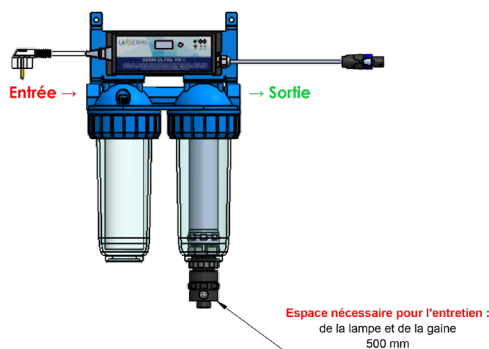
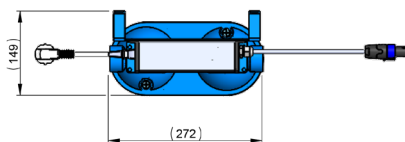

INSTALLATION

The **GERMI ULTRA 500 E** is installed on the main water supply. It can be secured to the wall with its mounting system. It must be positioned vertically. Sufficient space must be left below the **GERMI ULTRA 500 E** (at least 500 mm) or provide for easy dismantling of the unit (bypass) to replace the UV lamp and the cartridge.

The device must be protected against "water hammer" using a water hammer protection device (pressure vessel, shock absorber, etc.) if needed. It must be protected from frost, excessive heat and humidity (indoor installation).

MAINTENANCE

Maintenance is limited to the replacement of the UV lamp and the replacement or cleaning of the filter cartridge. The UV lamp has a maximal service life of 9,000 hours, after which water disinfection is no longer guaranteed.

The quartz sleeve protecting the lamp makes lamp replacement much easier: there is no need to drain or dismantle the GERMi ULTRA. The quartz sleeve may become clogged or lime scale deposits may form. It should be cleaned with a clean cloth and mild acid.

**The GERMi ULTRA 500 E can produce drinking water as long as the incoming water is chemically suitable for drinking water.*